

**LATHE  
TAPER  
ATTACHMENT**

**60<sup>th</sup>  
ANNIVERSARY  
SPECIAL**

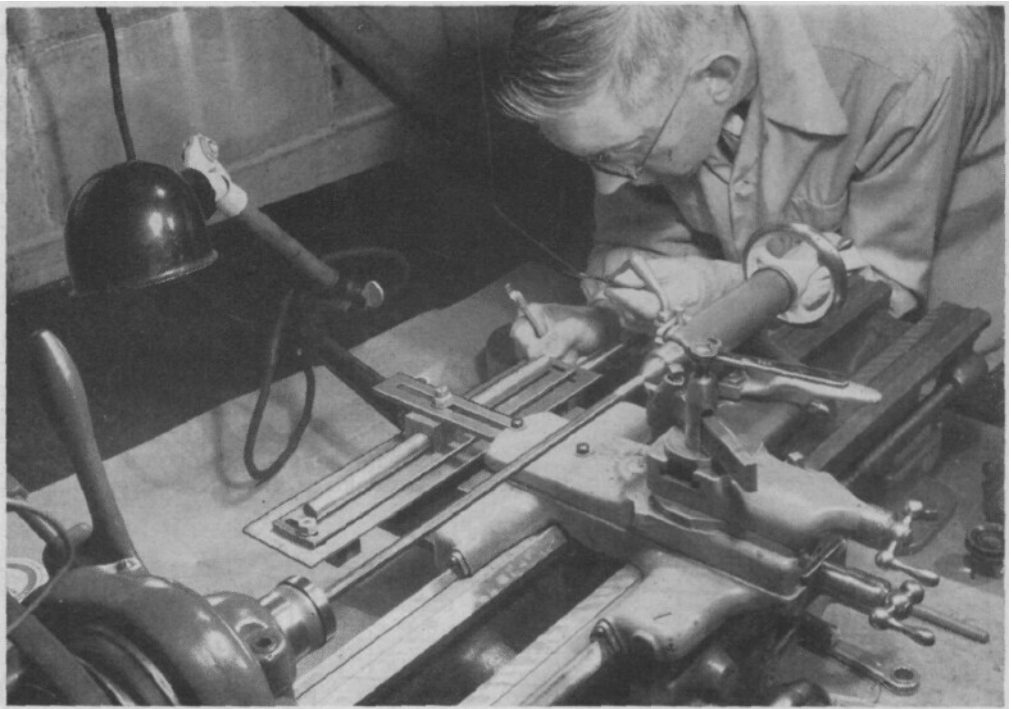

1. SHOP-MADE TAPER ATTACHMENT mounted on small lathe can be adjusted to turn outside or inside tapers on work mounted between centers or in a chuck for taper boring. Attachment is made entirely from stock materials

### By Waller E. Burton

**T**URNING A TAPER by offsetting the tailstock of the lathe is a common practice but the method has several disadvantages. In turning a taper by offsetting, the lathe centers are out of alignment which can result in inaccuracies due to burring of the center holes in the work, also possible scoring of the lathe tail center. Only work mounted between centers can be tapered by the offset method; taper boring cannot be done. In small shops where the amount of taper work does not warrant the outlay for a conventional taper attachment it is possible, using stock materials, to make one to fit nearly all small lathes.

The taper attachment pictured in Fig. 1 and on the opposite page was made to fit a 9-in. lathe. As a rule the parts dimensioned in Fig. 6 through 8 will be suitable for various makes of 9-in. lathes and possibly those of slightly larger or smaller swing. Note that two of the parts are not fully dimensioned, the cross-slide connector and the bracket. Figs. 7 and 8. You can use .125 or 1/4-in. stock for the connector, depending on the clearance. The 5-in. dimension on the bracket was found adequate for the lathe pictured, but may not be for all lathes in this size range. The bracket can be made

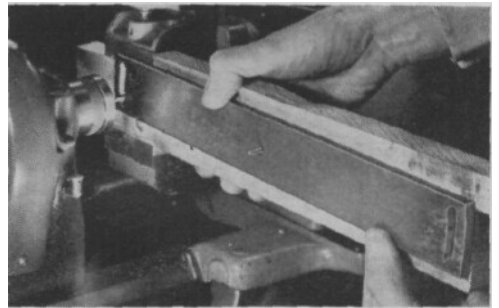

2. SLOTTED ENDS of swiveling bar, or carrier, are finished in lathe with milling cutter or rotary file

3. SLIDE BLOCKS are first bored offcenter, then reamed. If desired, blocks can be made from brass

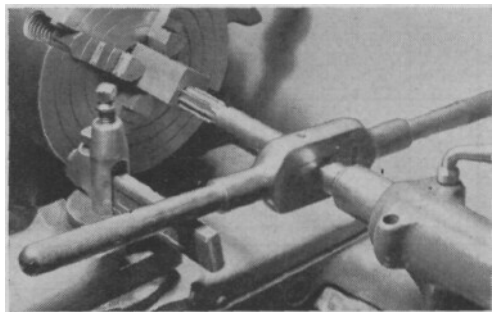

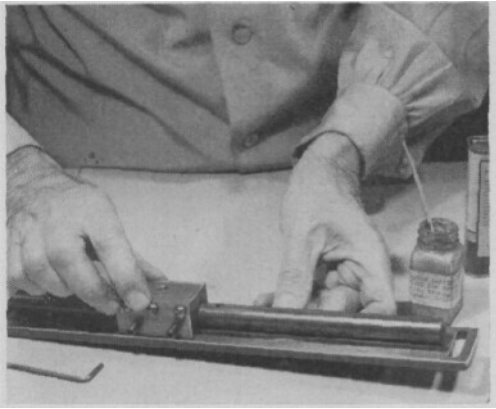

4. SLIDE BLOCKS should be lapped after reaming to assure smooth operation. Drill-rod track is coated with lapping compound. Block is stroked by hand

from a short length of heavy steel angle or can be made by welding two pieces of  $\frac{1}{2}$ -in. flat steel at a 90-degree angle. The bracket is screwed to the flat on the back face of the lathe carriage, Fig. 5. The dimensions on the angle bracket carrying the V-way clamp, Fig. 6, also should be checked with your lathe before cutting stock. The lower track, Figs. 5 and 8, should be parallel with the lathe ways.

The slides, Fig. 5, are bored offcenter and reamed as in Fig. 3. After reaming, saw cuts (or milling cuts) are run through into the bore and into one side as indicated. Then when the capping piece is screwed in place, the setscrews, with locknuts, provide for clamping the slides at any point along the tracks. Then each slide is lapped to its track, using a lapping compound and a full-length stroke as in Fig. 4. After roughing

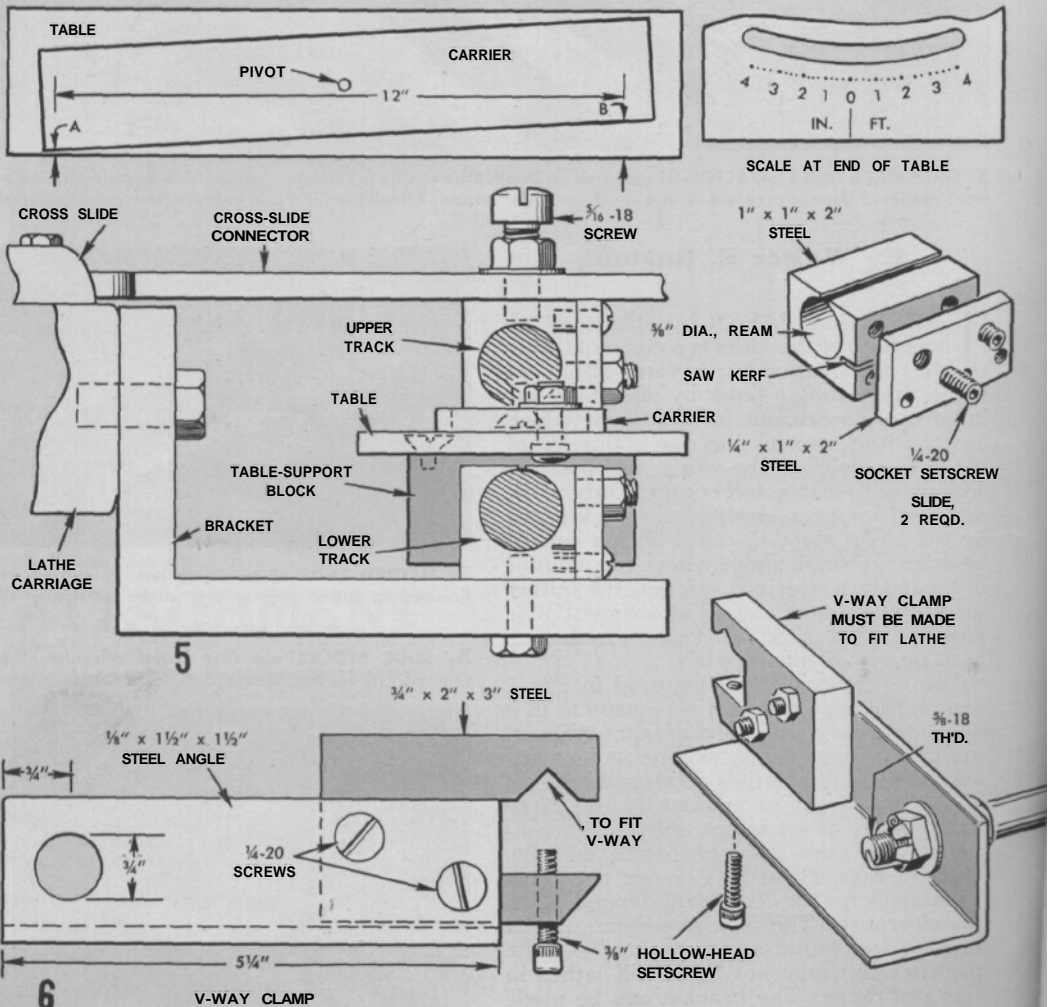

6-A DEPTH MICROMETER is used to make close measurements when calibrating

out undersize with drill and hack-saw, the curved slots near the ends of the carrier and table can be finished with a rotary file (or milling cutter) as in Fig. 2. Each member is pivoted on a piece of hardwood which is locked in the milling vise. Then the work is hand-fed to the file or cutter.

Finished parts and partial assemblies are pictured in Figs. 9 through 12. In Fig. 11 the parts are set for a 1-in.-per-ft. taper. The first step in calibrating is to check alignment of the upper track with the edge of the carrier nearest the lathe and also alignment of the

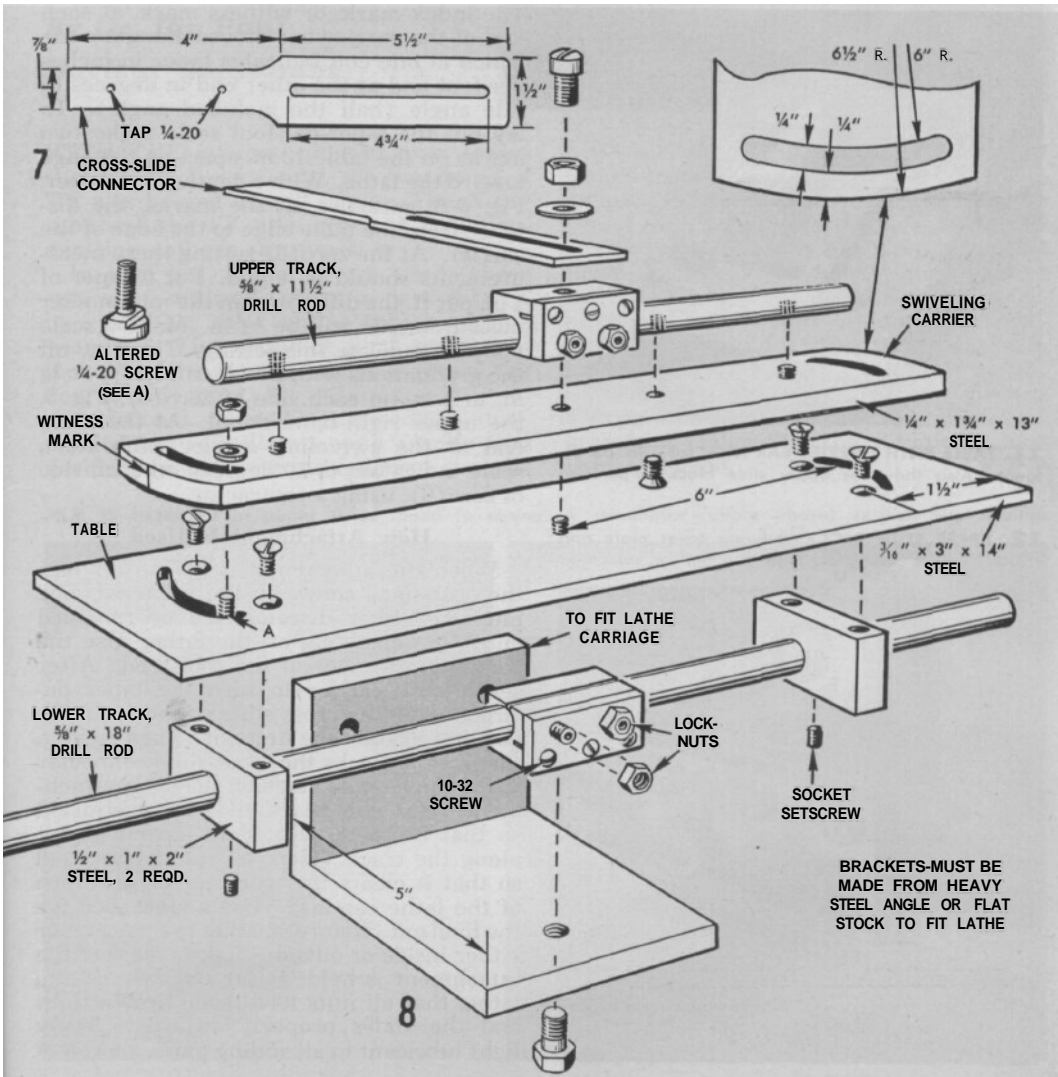
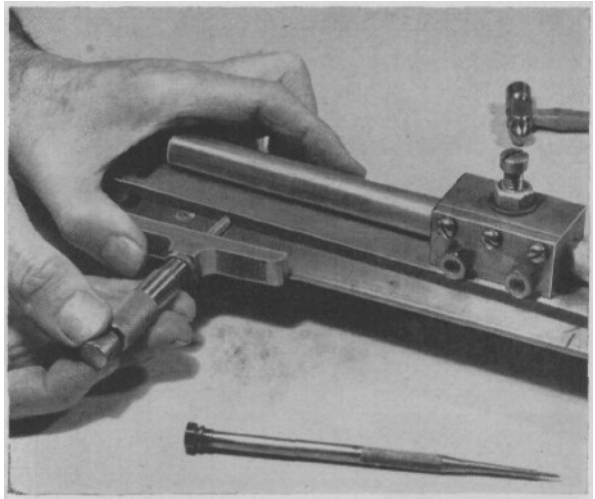

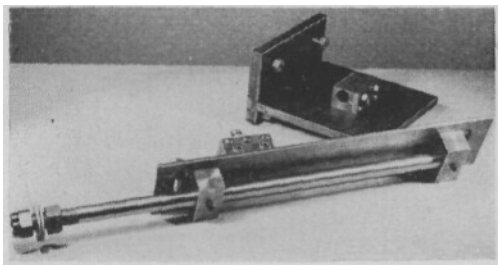

**9. TABLE AND ANGLE BASE** showing lower track and support blocks setscrewed to underside of table. Slide blocks are shown in relative positions on table and base. These parts are all made from stock materials

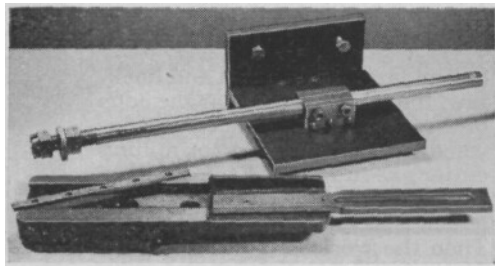

**10. CROSS-SLIDE CONNECTOR** is bolted to underside of lathe compound as in foreground. In background lower block is shown in position on built-up base. Slide block should be lapped to track with fine compound

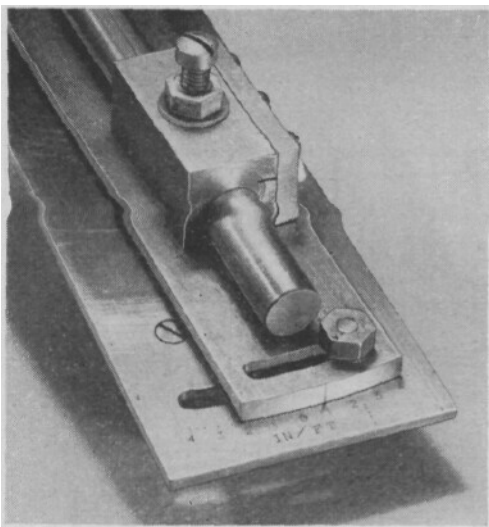

**11. TABLE WITH CARRIER BAR** is set for 1 in.-per-ft. taper. Also shown is upper slide block in position

**12. UPPER SLIDE BLOCK** showing cover plate and screw holding connector. Note the hollow setscrews

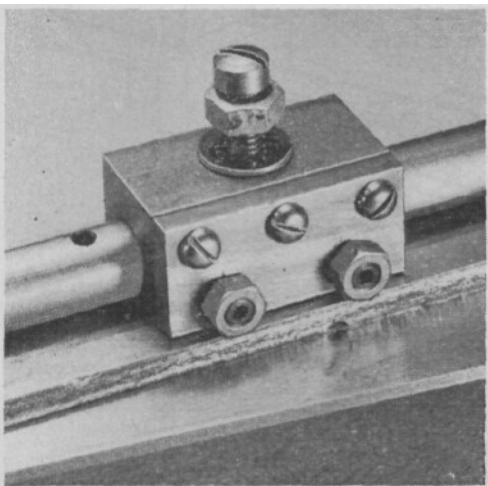

lower track with the edge of the table nearest the lathe bed. The two check points should be 12 in. apart as in the upper detail, Fig. 5. Make a note of any variation. The index mark, or witness mark, at each end of the carrier bar moves along a scale which at one end indicates taper in inches per foot and at the other end in degrees of side angle (half the included angle). To lay out the taper-per-foot scale make two marks on the table 12 in. apart on the edge toward the lathe. With a depth micrometer, Fig. 6-A, measure, at the marks, the distance from the table edge to the edge of the carrier. At the zero(0) setting these measurements should be equal. For a taper of 1 in. per ft. the difference in the micrometer measurements will be  $\frac{1}{2}$  in. Make a scale mark to indicate this setting. Then lay off the graduations with dividers from .125 or  $\frac{1}{8}$  in. to 4 in. on each side of zero(0), Fig. 5, the upper right-hand detail. At the other end of the swiveling carrier calibrate a scale indicating to 10 degrees on each side of zero (0), using a protractor.

### How Attachment Is Used

When the attachment is set up for use, the cross-feed screw on the lathe carriage must be either disconnected or removed entirely, depending on the lathe. Use the compound to control the tool feed. After setting the carrier to turn the taper desired, move the cross slide so the tool is in position to start the first cut. Then tighten the nut that locks the cross-slide connector to the upper slide block on the taper attachment. The slide block should be adjusted so that there is no play in its movement along the track. Back off the cutting tool so that it clears the work for each return of the lathe carriage. Use a slow feed for the final cut. Before starting to turn a taper either inside or outside, make sure that the attachment is held rigidly in place on the lathe, that all nuts have been drawn tight and the slides properly adjusted. Apply light lubricant to all sliding parts. \* \* \*